

 <p>MICROELETRICA SCIENTIFICA MILANO ITALY</p> <hr/> <p>testreportterrabilmsrésistan ces</p>	<h1>TEST REPORT</h1>	<p>DOC. NR. : BC2201/03/01</p> <hr/> <p>Rev. 0 Pag. 1 di 18</p>
---	----------------------	--

EARTHING RESISTOR

- Customer : ABB Transmission & Distribution
- Project : 033480/4220-PTPS
- Purchase order : 330080-1
- Acknowledgement : O NE 03 08 005
- Equipment under test : Earthing resistor 40kV/200A/200Ω
- Test references : 325kV BIL, HV Terminal to Ground

Ortile

0	Issue	31.10.03	G. Coti	Ortile
Rev.	Description	Date	Prepared	Approved



TEST REPORT

DOC. NR. :
BC2201/03/01
 Rev. 0
 Pag. 2 di 18

Index

1	TEST OBJECT	3
2	MEASUREMENT OF RESISTANCE AT D.C. CURRENT	3
	TERRORE. IL SEGNALE NON È DEFINITO.	
2.1	COLD OHMIC VALUE ON A COMPLETE UNIT.....	3
2.1.1	Measurement before the "Lightning impulse voltage withstand test".....	3
2.1.2	Measurement after the "Lightning impulse voltage withstand test".....	3
6	LIGHTNING IMPULSE VOLTAGE WITHSTAND TEST	4
6.1	TEST CONFIGURATION.....	4
6.2	LIGHTNING IMPULSE WITHSTAND LEVEL (LIWL).....	4
6.3	SPECIFIED TESTS.....	4
6.4	TEST CIRCUIT	5
6.5	HIGH VOLTAGE TERMINAL TO GROUND	6
6.5.1	Calibration (Positive and negative polarity).....	6
6.5.2	Tests results	6
8	INSTRUMENTS LIST USED FOR THE ABOVE MEASUREMENTS/TESTS	6
9	ENCLOSURES (OR ATTACHMENTS).....	6



TEST REPORT

DOC. NR. :
BC2201/03/01
Rev. 0
Pag. 3 di 18

The test on a complete unit was carried out on 31.10.2003 at MICROELETTRICA SCIENTIFICA.

Test performed by : Mr. M. Cervelli (MICROELETTRICA SCIENTIFICA)

Test witnessed by : Mr T. Ortile (MICROELETTRICA SCIENTIFICA)

Test results : Passed

1 Test object

- One Earthing Resistor in two stacked modules :dimensions and data as per dwg. C NE 03 08 005- 1
- Serial number : O NE 03 08 005 -1 / 001
- Year of construction :2003
- Ohmic value at 20 °C (complete resistor) :200 Ohm $\pm 7,5\%$
- Nominal current and duty time :200 A / 30 sec.
- Lightning impulse withstand levels
 - High voltage terminal to ground : 325 kV_{crest}

2 Measurement of resistance at d.c. current

2.1.1 Measurement before the “Lightning impulse voltage withstand test”

- Measured total value at ambient temperature R_1 : 193,6 Ohm (limit values are 185 to 215 Ohm)
- Ambient temperature t_{amb} : 19 °C
- **Test results** : **within acceptance limits**

2.1.2 Measurement after the “Lightning impulse voltage withstand test”

- Measured total value at ambient temperature R_1 : 193,7 Ohm
- Ambient temperature t_{amb} : 20 °C
- **Test results** : **within acceptance limits**

3 Lightning impulse voltage withstand test

3.1 Test configuration

- Withstand impulse voltage tests according to the following configuration :

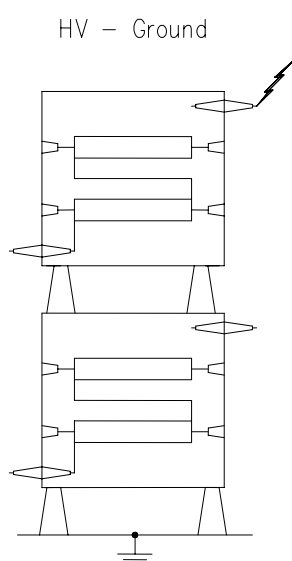

3.2 Lightning impulse withstand level (LIWL)

- HV-G High voltage terminal to ground $325 \text{ kV}_{\text{crest}}$

3.3 Specified tests

- 1 reduced wave, positive and negative polarity
- 15 full waves, positive and 15 negative

3.4 Test circuit

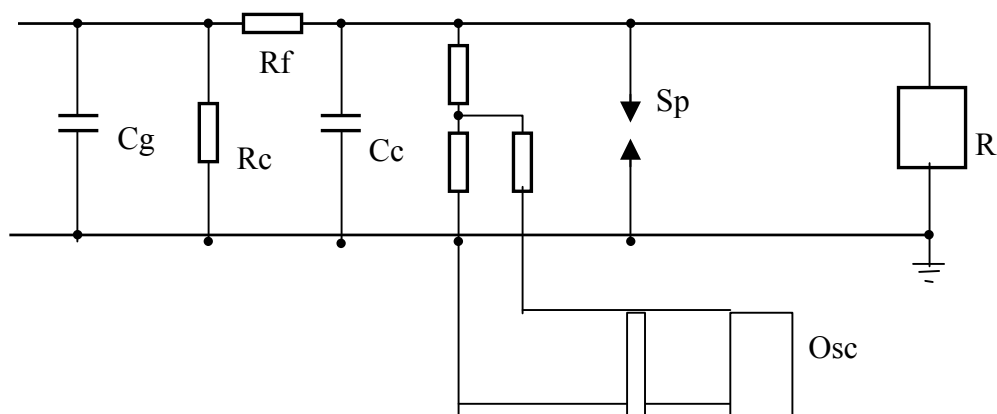

Cg	Capacitors banks	8 x 0.5 μ F - 100 kV (DUCATI)
Rc	Tail resistor	see § 6.5 – 6.6 – 6.7
Rf	Front resistor	see § 6.5 – 6.6 – 6.7
Cc	Capacitor divider	3000 pF - 500 kV (ICAR)
Sp	Sphera gap	No two balls \varnothing 250 mm
Osc	Oscilloscope	HP54645A/D (HEWLETT PACKARD)
R	Test object	



TEST REPORT

DOC. NR. :
BC2201/03/01
 Rev. 0
 Pag. 6 di 18

3.5 High voltage terminal to ground

3.5.1 Calibration (Positive and negative polarity)

Sphere distance	60 mm
Tail resistor (Rc)	4991 Ohm
Front resistor (Rf)	186 Ohm
Atmosferic pressure	1012 hPa
Air temperature	24 °C
Correction factor	0.985
Peak voltage	161 kV
Front time	1.38 μs (diagram nr. 48)
Tail time	80.26 μs (diagram nr. 49)
Voltage divider ratio (kV / V)	8.98

3.5.2 Tests results

Polarity	Crest voltage requested	A: Passed (⊕) Failed (x)																
		B: Oscillogram number																
		C: Crest voltage																
Positive	325 kV	A	⊕	⊕	⊕	⊕	⊕	⊕	⊕	⊕	⊕	⊕	⊕	⊕	⊕	⊕	⊕	
		B	55	56					57				58					59
		C	175	331	329	326	325	325	314	320	328	329	330	328	326	325	326	331
Negative	325 kV	A	⊕	⊕	⊕	⊕	⊕	⊕	⊕	⊕	⊕	⊕	⊕	⊕	⊕	⊕	⊕	
		B	50	51				52				53					54	
		C	189	351	350	349	352	351	347	335	326	314	320	327	324	326	320	317

4 Instruments list used for the above measurements/tests

- Digital ohmmeter CROPICO – Mod. D04A – No. 0090
- Checked on 08.05.2003 - Due date 25.07.1999 8.5.0./8.11/03
- Digital multimeter ABB METRAWATT – Mod. MA5D – No. 0056
Checked on 07.11.2002 - Due date 07.11.2003
- Digital multimeter ABB METRAWATT – Mod. MA5D – No. 0064
Checked on 13.11.2002 - Due date 11.11.2003
- Oscilloscope HEWLETT PACKARD – Mod. 54645A/D – No. 0073
Checked on 08.05.2003 - Due date 08.05.2004

5 Enclosures (Or Attachments)

- Diagram 48 to 54, *Lightning impulse voltage withstand test – H.V. to Ground – Negative polarity.*
- Diagram 55 to 59, *Lightning impulse voltage withstand test – H.V. to Ground – Positive polarity.*



MICROELETRICA SCIENTIFICA
MILANO ITALY

TEST REPORT

DOC. NR. :
BC2201/03/01
Rev. 0
Pag. 7 di 18

Diagram N. 48

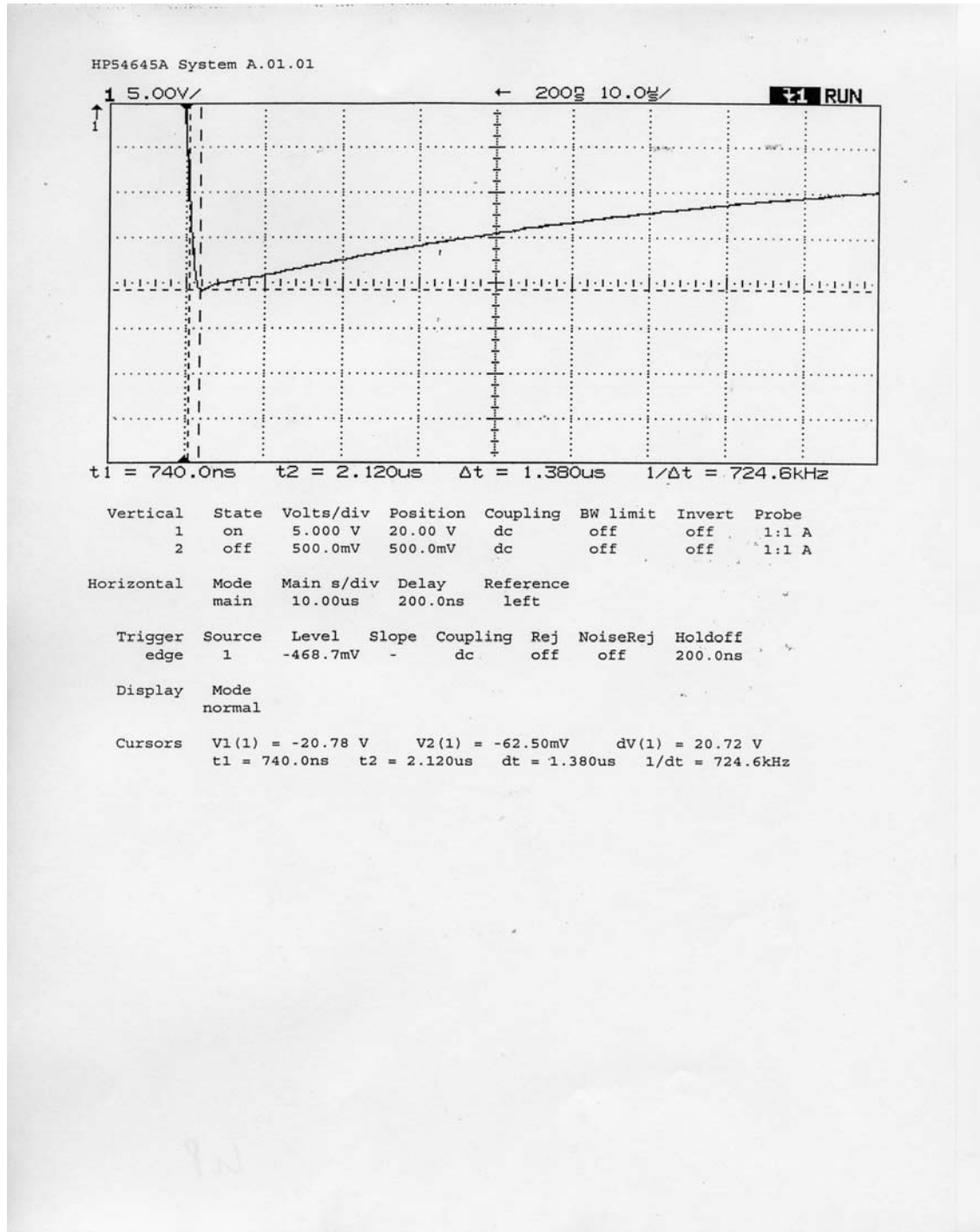



MICROELETTRICA SCIENTIFICA
MILANO ITALY

TEST REPORT

DOC. NR. :
BC2201/03/01
Rev. 0
Pag. 8 di 18

Diagram N. 49

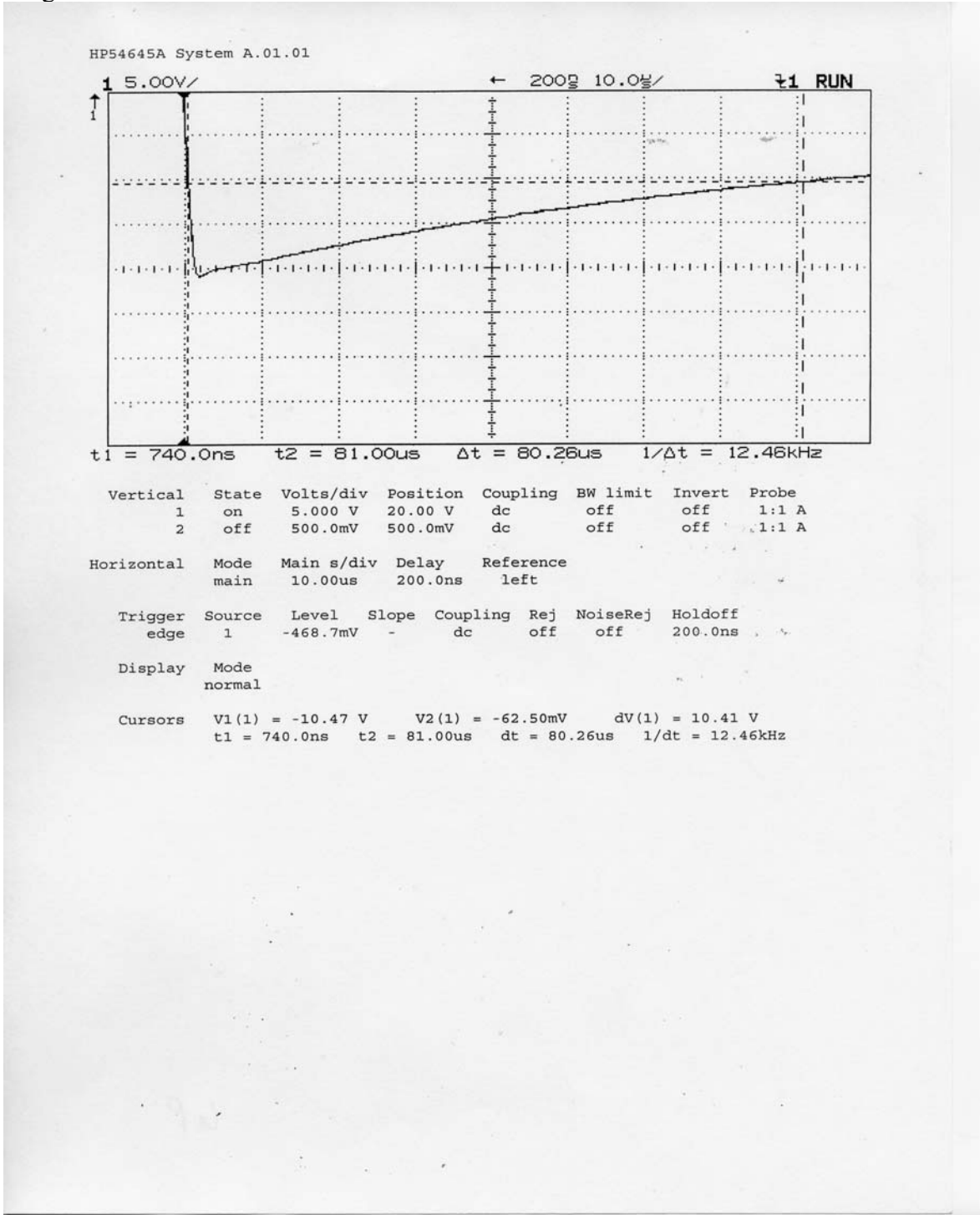

Diagram N. 50

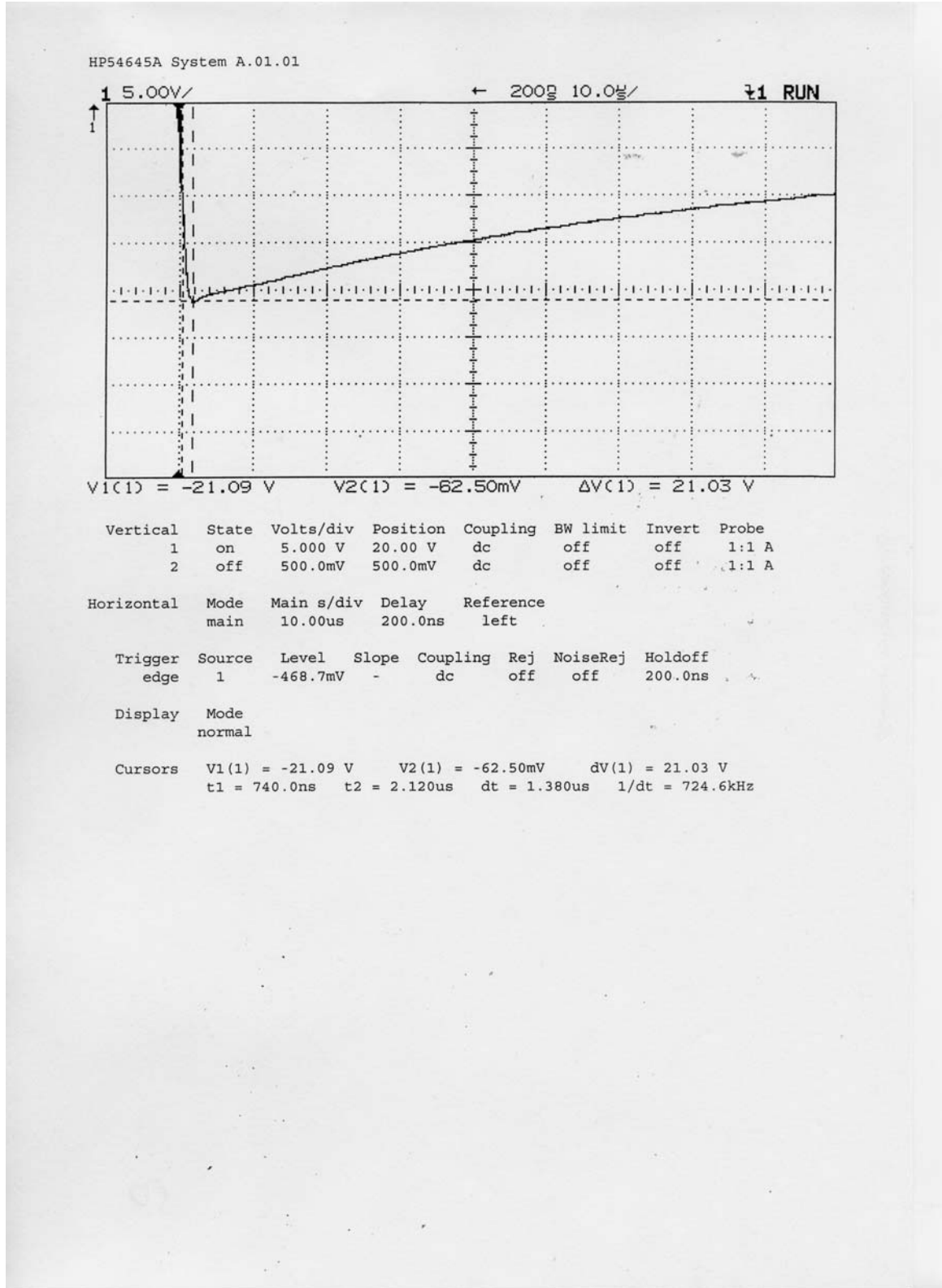

Diagram N. 51

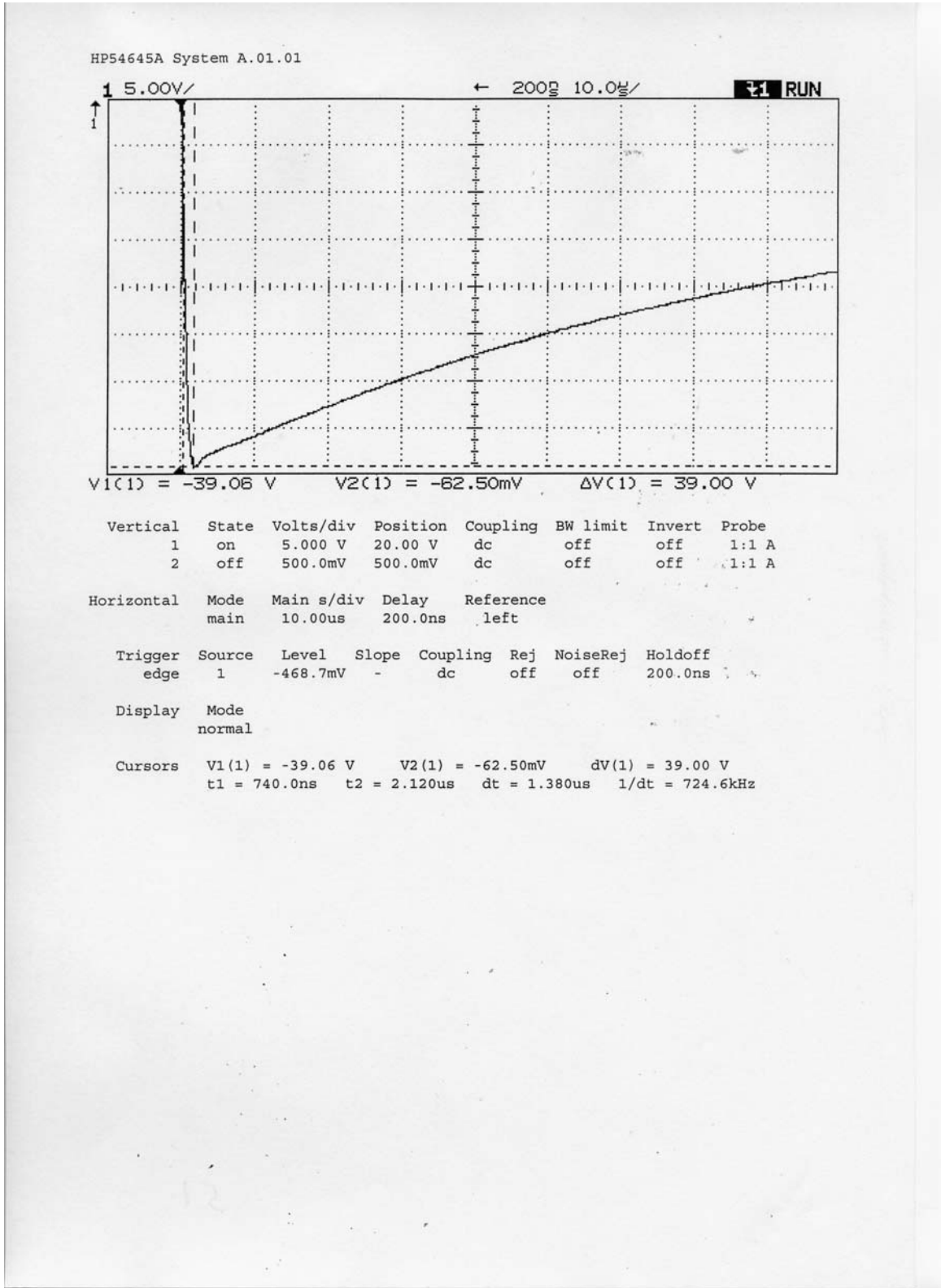

Diagram N. 52

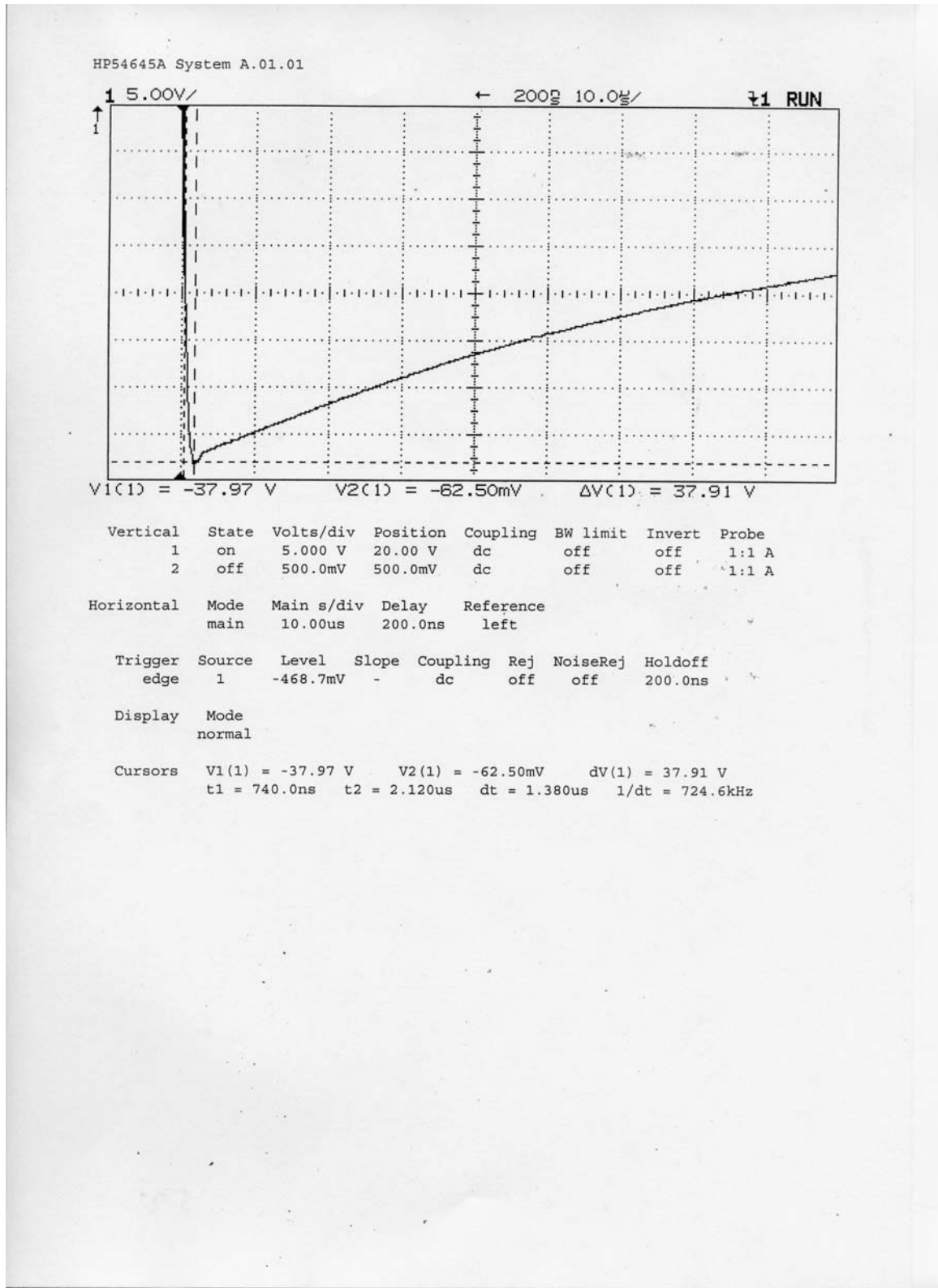

Diagram N. 53

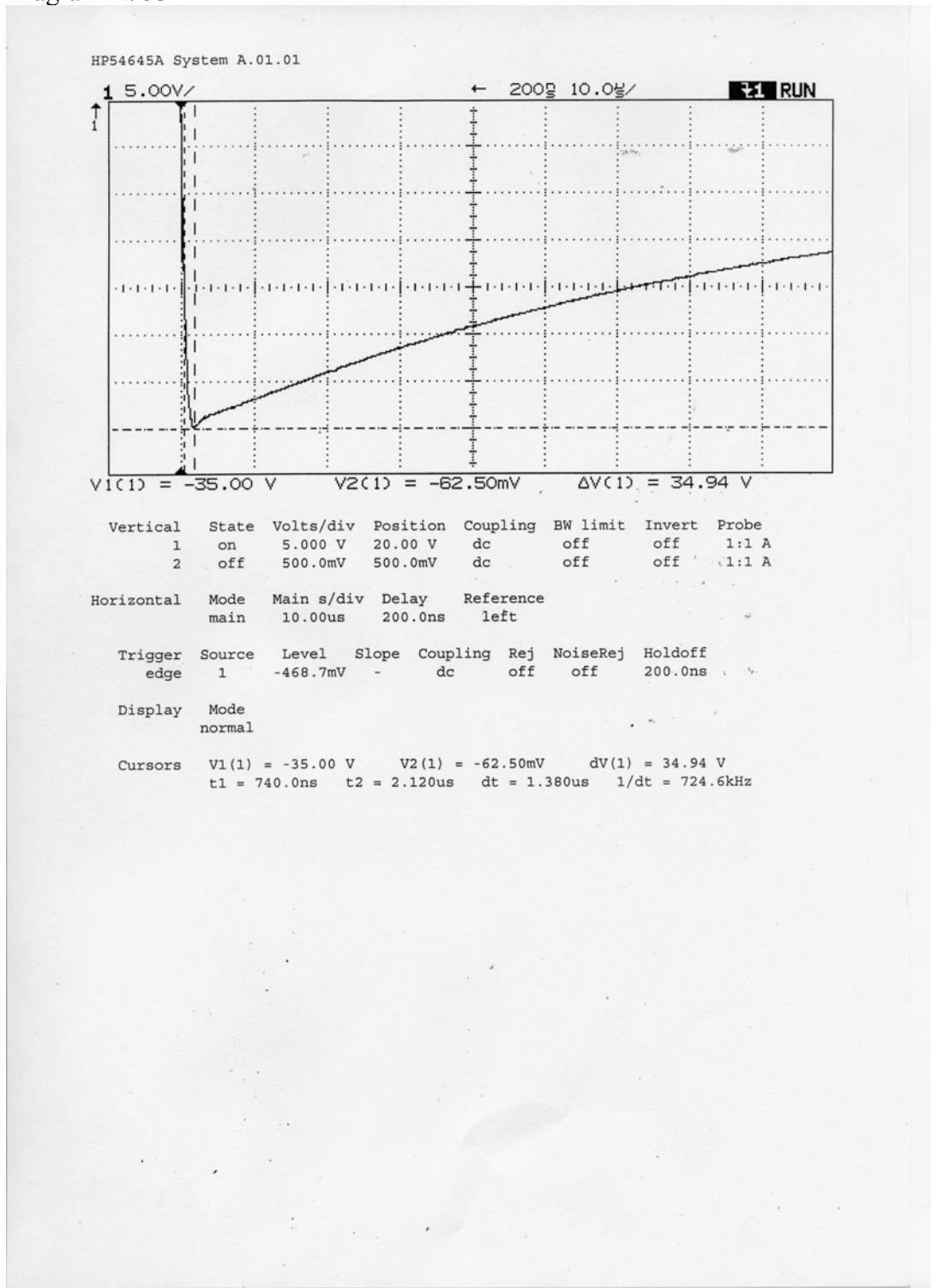

Diagram N. 54

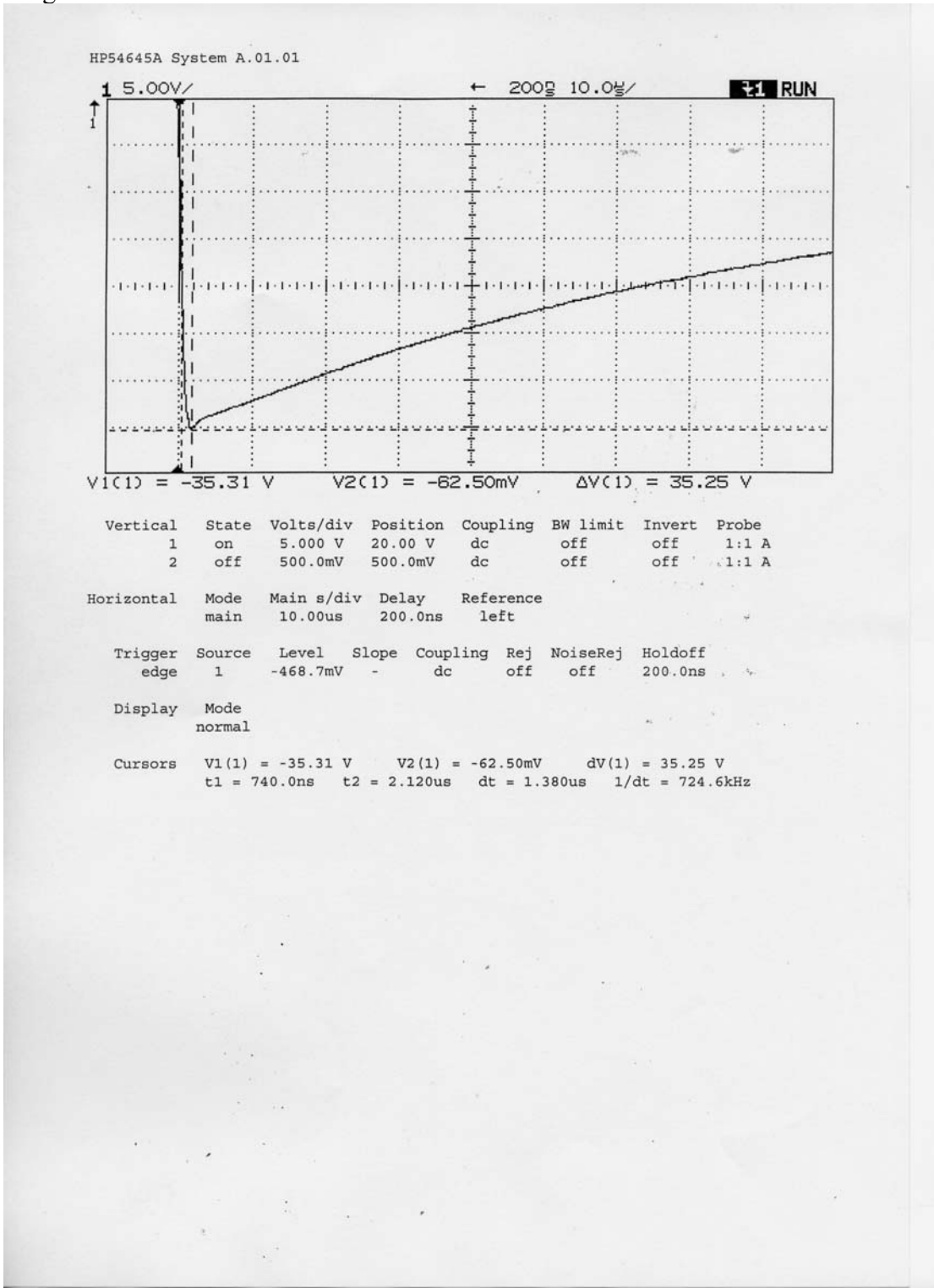

Diagram N. 55

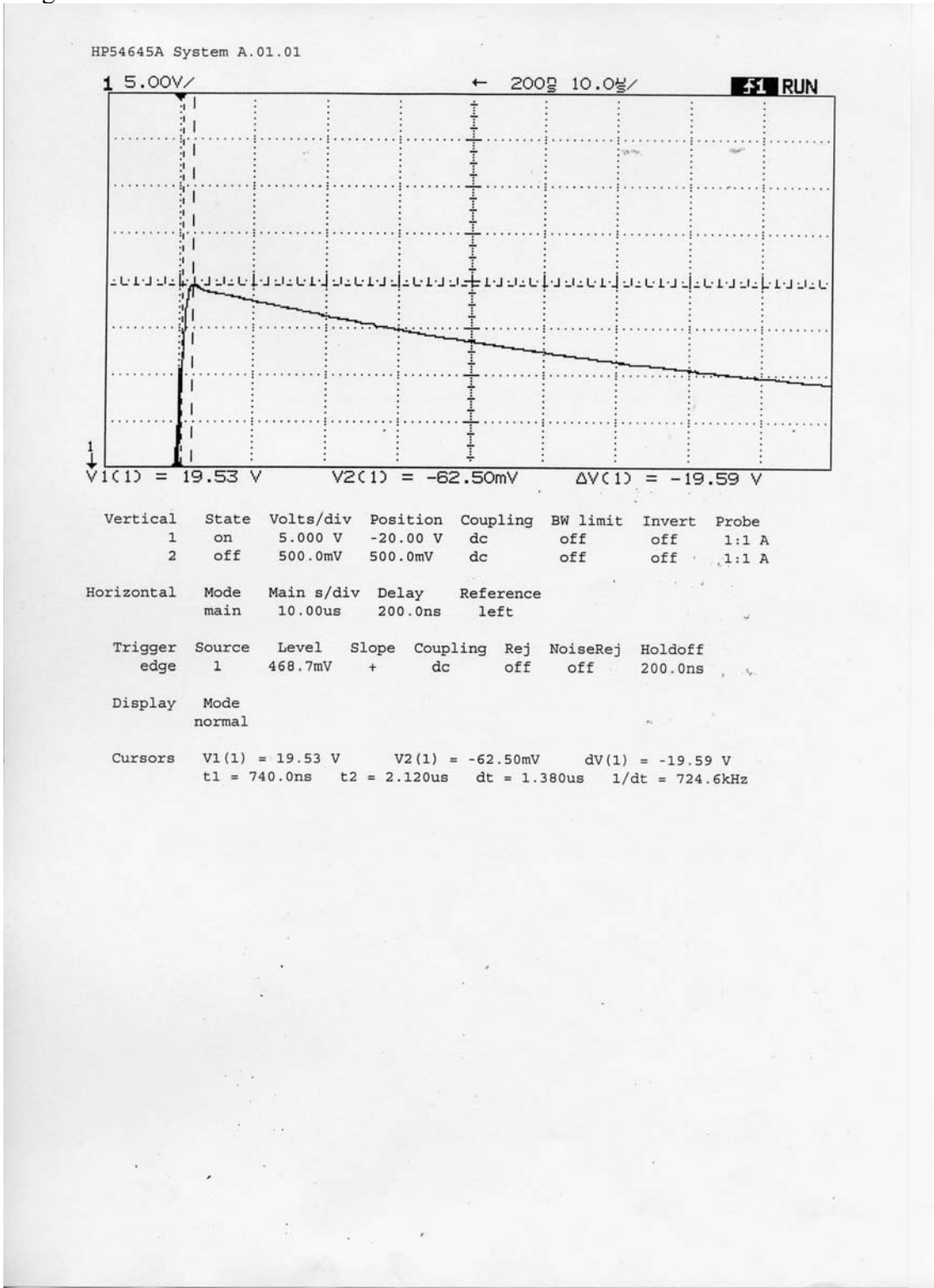

Diagram N. 56

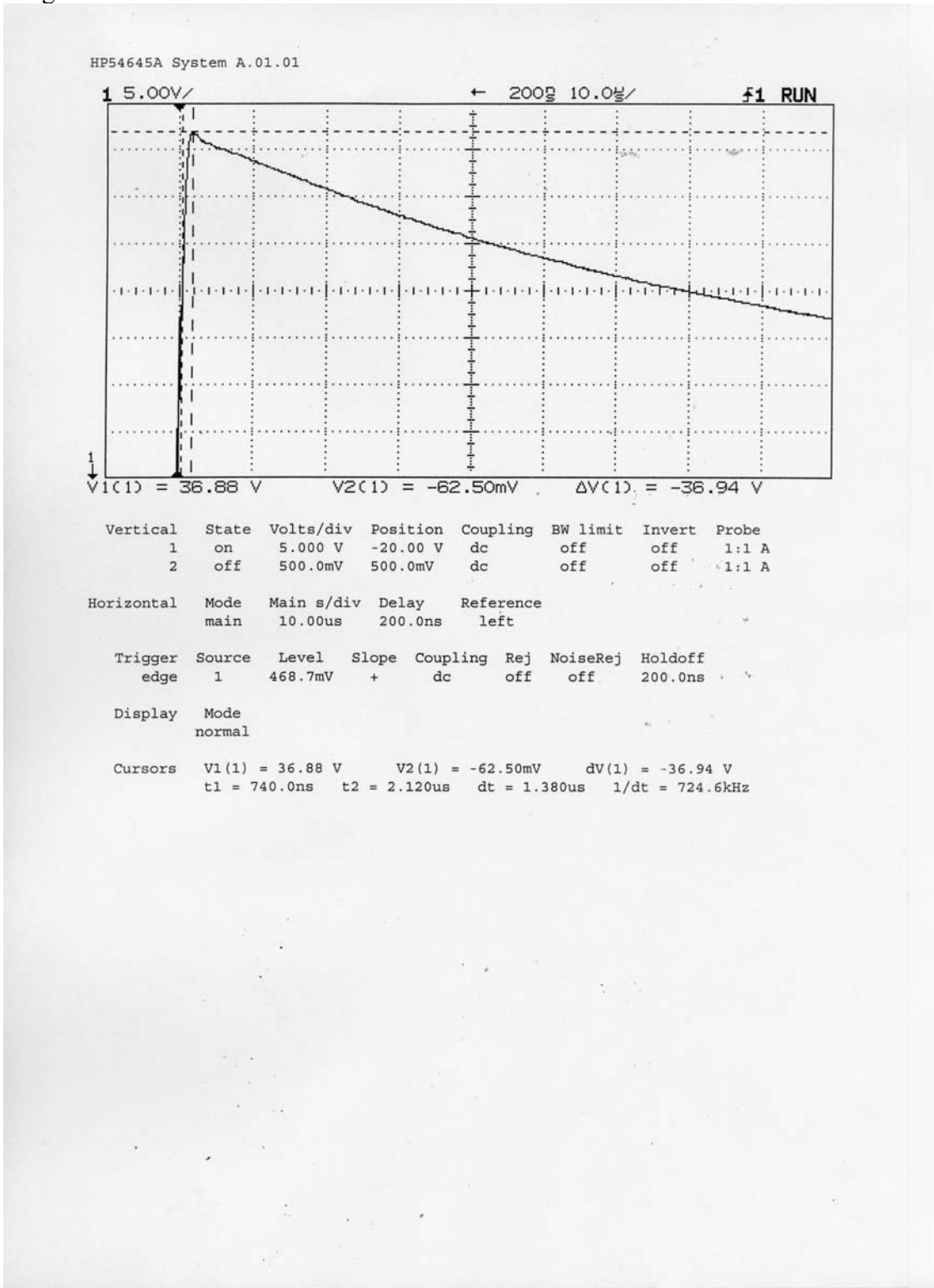

Diagram N. 57

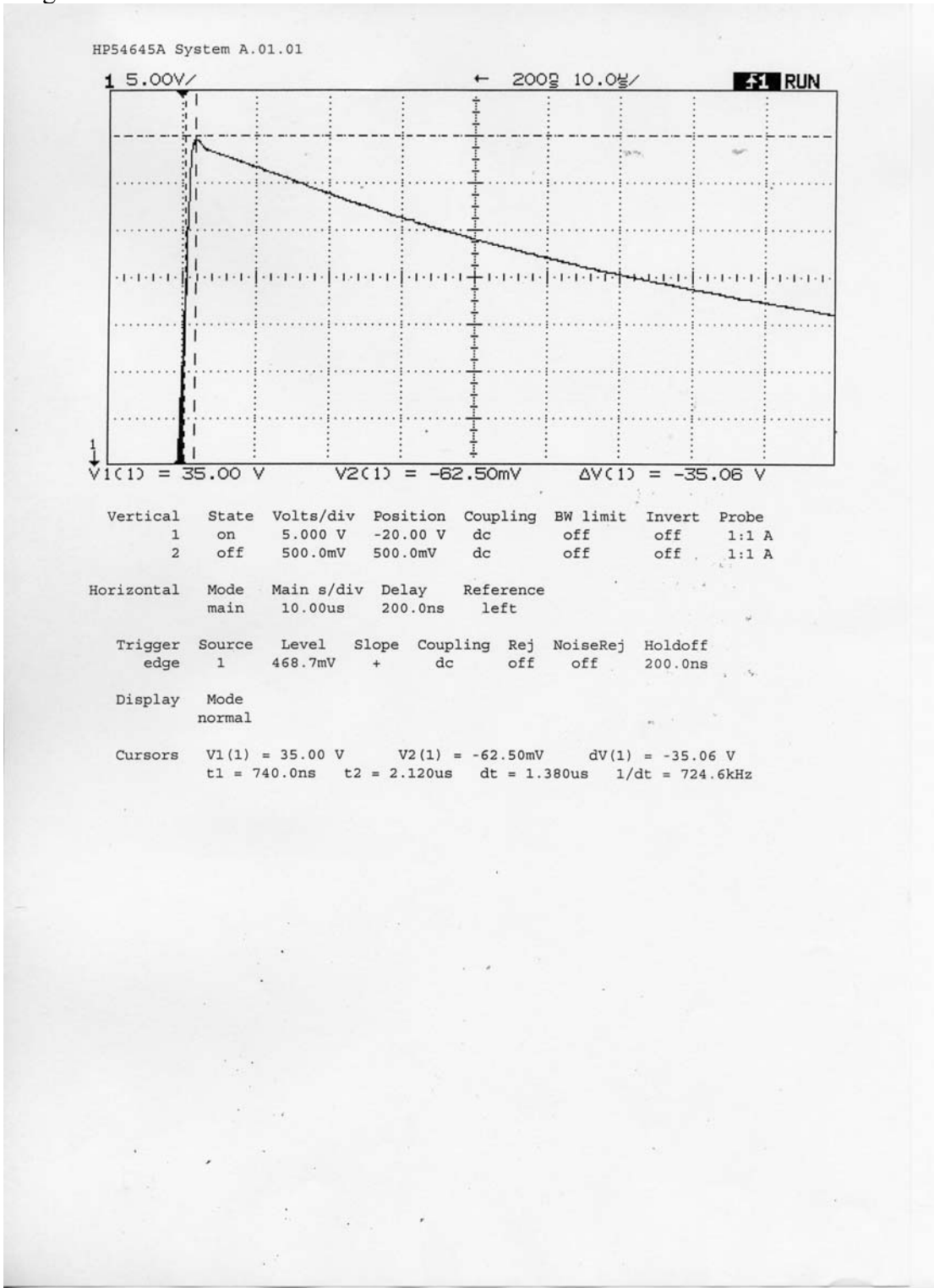

Diagram N. 58

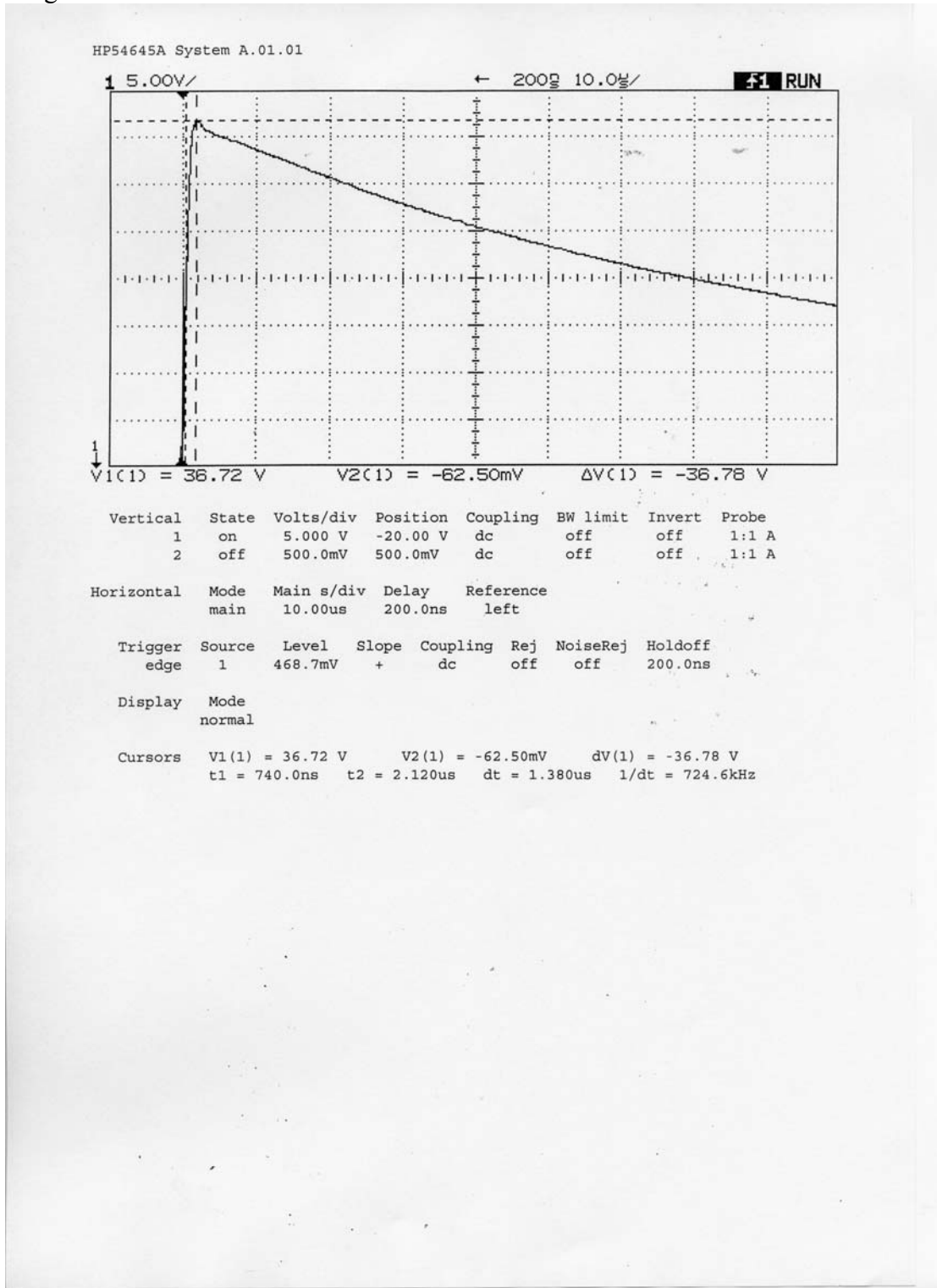

Diagram N. 59

